

HIGH ELECTRICITY BILLS WHAT CAN YOU DO?

Have you ever felt uneasy when you have got high electricity bill and you do not know why it is high and what you can do? Blaming the utility company is a common thing that most people do. But there are ways to find out why the bills are high, which are not too technical and can be done quite easily.

First and foremost, never just look at the amount in rupees on electricity bill to say that electricity bill is too high. Observe the units consumed on the bill and compare it to the units consumed in the previous month and the same month in previous year. If the units consumed are comparable then it is highly likely that the power tariff applied on the electricity bill by your utility has changed resulting in higher amount in rupees. It is also possible that the fixed cost component on the electricity bill might have changed. This is however usually not very significant.

If you feel that your units consumed are normally high then the best thing that you can do to confirm that is by comparing your electricity bills with other people with similar kind of household like yours. This activity can give you a good benchmark on energy usage for a dwelling like yours and will help you understand if your electricity bills are really high or not.

If your units consumed are much different from previous month or same month last year, then the first thing that you can do is check your electricity meter reading and make sure that the bill shows the right meter reading. In India, most of the electric meter reading is done manually and thus there is a potential of human error in the same. This step can assure you that the meter reading shown is right.

If the meter reading is right then you need to evaluate that there are no electricity leakages in your house. To do this, first you need to switch off the mains (power mains) in your setup and check if the meter is moving/changing or not. If it is moving/changing then either the meter is broken in which case if you show that to the utility they will give you back the overcharged money, or some more wires (not belonging to you) are connected to your meter which you need to get check by an electrician.

If the meter does not move on switching off the mains, then the next thing that you can do is, put off all the appliances and turn on the mains. If the meter moves then that means that there is faulty wiring in your setup which is causing electricity leakage and you need to get an electrician to find and fix that. It is also possible that an appliance is connected directly to the lines without a switch and you need to make sure that it is corrected.

Finally you can check electricity consumption of individual appliance by keeping everything else off and leaving the appliance on and observe the meter movement. To do all of this you will need to give a lot of time as 1 unit of increases on a meter when 1 kWh of electricity is used, which is equal to running 100 W bulb for 10 hrs or running a 1 ton AC for about an hour.

Simple steps mentioned above can help you do a self-energy audit. Alternatively, many utilities in our country are providing audit facilities these days which can be availed at minimal charges.

Defective electricity meter ?what you can do.

Electricity meters just like any other device or appliance can go wrong any time. Although it does not mean that they are the sole reasons of high electricity bills, but it can be one of the issues. The first thing that you can do is to validate the electricity bill amounts using some guidelines that are available on our website. And if it is found that the electricity meter is defective, then you need to "act". With this article we will try to explain what does it involve to "act" and how can it be brought back to a normal state.

First Step

If you have identified or felt that the electricity meter is faulty, the first thing that you should do is: inform your electricity distribution company. The meter may belong to the consumer or electricity distribution company but the responsibility of maintaining it lies solely with the electricity distribution company. In fact as per CERC (Central Electricity Regulatory Commission) regulations, electricity distribution companies should test the meter once every five years and the cost of the same has to be borne by the company. CERC regulations also state that responsibility of safety of meters lies with the customer.

If you wish to verify the accuracy of the meter then you need to submit an application to the electricity distribution company. Some electricity distribution companies have a fee to make this application. The meter can be tested in distribution company's laboratory or any other authorized laboratory (laboratory authorized by state electricity regulatory commission). The meter has to be tested within a few months (e.g. 2 months in Maharashtra) and the consumer can request a copy of the report of the same.

What if your problem is not attended?

You made an application but your meter was not tested, or no one responded to your complaint or you did not get a report or you still not satisfied. The next thing that you can do is: register your complaint with Consumer Grievance Redressal Forum which is an independent entity dedicated to handle all consumer complaints related to electricity. If you are still not satisfied by the response from the Grievance Redressal forum, you can always go to State Electricity Ombudsman appointed by the Joint Electricity Regulatory Commission for the state of Goa and Union Territories. The ombudsmen have authority over the distribution companies and can help you resolve your disputes with the electricity distribution companies.

Inform immediately if you feel meter is faulty

If a meter is found faulty, most distribution companies will adjust bills of only last few months. So it is very important to act quickly if you find that the meter is faulty. Similarly companies can recover bills of only for few months if the meter has stopped working completely. Thus do not wait for long to get your meter tested if you feel that the meter is getting wrong readings.

Meter can go wrong either way

Meter can go fast and can go slow as well. If it is found that the meter is slow, then the excess amount will have to be paid by the consumer. It is important to note that if you have a very old mechanical meter, it is likely that it can be running slow. Many people complain of higher electricity bills when their meters are changed to electronic meters. But the fact of the matter is, old mechanical meters tend to get slow and whenever they are replaced with new functioning electronic meters, people tend to get electricity bills higher than what they used to pay. This happens because the new meters show the correct readings.

So act soon if you feel that your electricity meter is not correct.

ELECTRICITY METERS READING COMPARISON: Electromechanical meters, Electronic meters and Smart Meter

The expenses incurred on electricity consumption are one of those expenses which one has to bear on a regular basis. Every month you receive a bill of the electricity which you have consumed through different appliances. When the bill is surprisingly higher in a certain month, you start thinking, "How come my bill is so high than the previous month, given that my electricity consumption pattern has been the same?" In fact, some people are also of the opinion that electronic meters run faster than electromechanical meters. So is it true? No.

If you have come across this situation, then let us assure you that you are not the only one who felt like this. In fact, we regularly receive queries regarding the same issue wherein people say that despite their electricity usage being the same as the previous month, their electricity bills have spiked. A very important reason for this lies with the electricity meters.

How does that happen? Let us see.

What are electricity meters (energy meters)?

An electricity meter is a device which measures the total electrical energy (or electricity) consumed by the appliances which draw electrical energy from the main power supply at a house or an official space and so on. Electricity meters are a common sight in the households today. When you look at a meter, what do you see? You see a few digits on it. What do these digits signify? These numbers (the reading on the meter) tell you how many units of electricity (mentioned as kWh in the meter) have you consumed so far. And your electricity bill is entirely dependent on this meter.

The reading on the meter is cumulative. So to determine the consumption reading of a particular month, the difference between the readings of that month and the previous month is calculated. The value which you get is the electricity consumption of that particular month. Now if this reading is small, it means that your consumption is low and consequently your electricity bill will be lower and if the reading is large, it means that your consumption is high and consequently your electricity bill will also be high.

Types of electricity meters

The electricity meters come in different types. These are:

1. **Electromechanical meter:** Electromechanical meters were very common in India few years ago. They still are very popular in the rural areas where the penetration of the modern technology is not as high as it is in the urban areas. The working of electromechanical meters is fairly simple. There is a non-magnetic metallic disc attached to it internally which rotates depending upon the power passing through it. So if the power passing through is high, then the disc rotates faster and when the passage of the power is low, the disc rotates slower. The rate of the rotation in turn decides the reading on the electricity meter. Higher the number of rotation, higher is the reading and vice-versa. Since there is rotation of a disc involved, it is bound to consume some electrical energy itself to facilitate the rotations. The power of around 2 Watts is consumed to make it rotate and this power consumption is not registered on the meter.



2. **Electronic meter:** Electronic meters are becoming increasingly popular now-a-days in urban areas. An electronic meter has a LED/LCD display on which the readings of the electricity consumption of the connected appliances. The readings are digital in the electronic meters in

contrast to the electromechanical meters. These are much more efficient than the electromechanical meters in the sense that they do register every small unit of electricity consumed.



3. **Smart meter:** Smart meters are the newest addition to the type of electricity meters. They look similar to electronic meters but they are better than both the electromechanical meters and the electronic meters in the sense that in addition to providing the usual services of a regular meter, they are connected back to the utility through the internet. It means that there is no need of an official from the utility (which provides you electricity) to come at your doorstep and take the meter readings. The readings are automatically sent by the internet.
4. Electric energy use will be recorded every hour or less at your home. Smart meters will enable you to monitor your consumption more precisely so you can make more informed energy choices. Depending on the feature set, the meter may also notify the utility of a power outage or allow the utility to remotely switch electricity service on or off.



Problems with the electromechanical meter

Although the electromechanical meters have been quite common in the past years, there are certain problems that are attributed to them. Since electromechanical meters consist of moving parts, they are bound to undergo some wear and tear with the passage of time.

In a study conducted by Analogy Devices Inc. USA, it was found that the accuracy of a electromechanical meter deteriorates subject to the various environmental factors such as humidity, dust and dirt which significantly affect the operating accuracy of the electromechanical meter. Factors like corrosion, worn out gears and insects can render the electromechanical meter unable to capture the electricity consumption of a property accurately. The mechanical gear lubricants may dry up resulting in the breaking in the gear teeth which adversely affects the gear ratio. Also, the electromechanical meters may get mis-calibrated if they experience a sudden shock or vibration which may cause a jolt or a sudden stoppage of the rotating disk.

The change in accuracy of electromechanical meters as it ages is shown below in a graph.

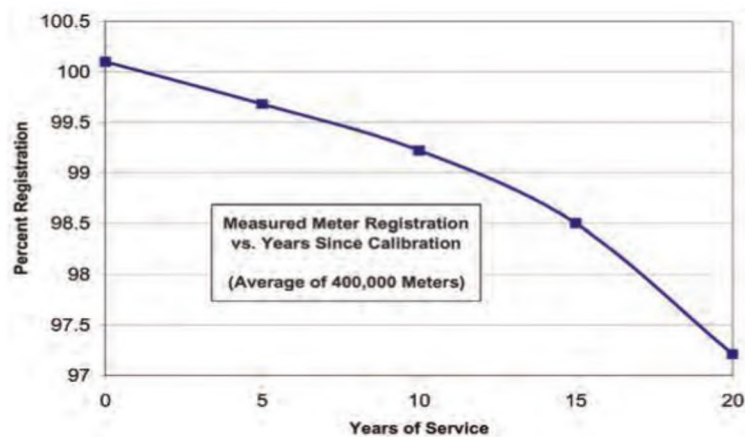

Electronic meters are a better than electromechanical meters because they do not contain moving parts in it which might get affected due to the various factors as listed above. Also they provide not only the consumed units (as is the case of electromechanical meters) but they also provide other information like the instantaneous and maximum rate of usage demands, [voltages](#), [power factor](#) and so on.

In a nutshell

If you see a sudden rise in your electricity consumption which is confounding you, it is highly likely that it might be caused due to the change in the type of meter at your place. If an electromechanical meter has been recently replaced by an electronic, it is possible that you might experience such a situation. Rest assured, it does not mean that your consumption has increased. It is just that your old meter was not able to account for the minute power consumption which the electronic meter is capable to do, causing the sudden increase in the electricity consumption.

FREQUENTLY ASKED QUESTION ON METERS

Why are electricity bills getting inflated after replacement of old electromechanical meters by new electronic meters or smart meters by the utilities?

There could be following reasons for inflated bills against the energy consumed:

- New meter is working satisfactorily but the wiring to meter, which was done earlier as per old electromechanical meter, is improper and not suitable for the new electronic meter.
- New electronic meter installed at the residence is running fast.
- Reasons other than indicated at (a) & (b) above

There are no reasons as indicated above but for the fact that energy consumed by the consumer is actually high.

How to check where the problems lie? Which of the reason(s) given at answer 1 above is/are applicable?

There is a simple check we can perform to find out whether the problem is in the new electronic meter or in the connections or household wiring etc. Before moving further the connection diagram of electronic meter indicated under answer 4 needs to be referred to. As per this diagram, the current entering the meter through phase wire and coming out of the meter through neutral wire

may be got checked from any qualified and experienced electrician. There could be any one of the following three observations of the electrician:

- i. Incoming and outgoing current is almost the same. If such is the case, then it may be concluded that connection to the meters are ok and there may be some problem in the meter itself (see question 3 for details with regard working of electronic meter).
- ii. Outgoing current is appreciably more than the incoming current. If such is the case, then somebody else's neutral wire has got connected to the meter's neutral wire and it is because of this reason that the meter is running fast. To be doubly sure, the following additional spot checks may be carried out:
 - a. Disconnect the neutral or switch off the MCB if it is installed in the neutral wire (load side). If the meter is still working, it means that there is an improper neutral connection
 - b. Switch off all electrical points in the house (including LEDs and indicating lamps) and check if the meter is working. If yes, then it means that there is an improper neutral connection. (See question 5 for details with regard to improper neutral connection.)
- iii. Outgoing current is less than the incoming current. If such is the case then it means that there is some leakage of current, earthing, etc in the building. This may be because of the old worn-out wiring in the house. To be doubly sure, following additional spot check may be carried out:

Disconnect all your electrical gadgets in the house (including small indicating lamps) and see if the meter is working. If yes, then it means that some leakage of current is taking place in the building (see question 6 for details with regard to effect of leakage current on billing).

How do you check as a common consumer at your end that your electronic meter is running correct before you approach distribution companies for their help?

We may check the working of energy meter with the help of a Licensed electrical contractor, in the following manner:

i) With the help of a duly calibrated standard lamp of 1000 watt:- A 1000-watt lamp if energized for one hour would consume one unit of electrical energy. Now, you may switch off all your electrical lamps/appliances, etc., in your house; record initial reading of the energy meter; let only 1000 watt lamp run for one hour and then record the final reading. If the difference of reading is one unit i.e. 1 kwh, it means that meter is working satisfactorily. Otherwise, it is running fast or slow. (This check can also be conducted with 500 W lamp run for 2 hours or 200 W lamp for 5 hours or 100 W lamp for 10 hours).

ii) With the help of meter constant which is indicated in the space meant for indicating name, etc attached to the meter e.g. x impulses /kWh i.e. X impulses per unit i.e. X times blinking of LED installed on meter for 1 unit consumption of electrical energy:- We may cross check this meter constant by actually counting the blinking of LED e.g. one unit should be registered by the meter in 3200 impulses i.e. 3200 times blinking of LED or $\frac{1}{2}$ unit should be registered in 1600 impulses or $\frac{1}{4}$ unit should be registered in 800 impulses and so on. If meter constant indicated on the meter matches with your actual impulse count/number of blinks of LED, it means that the meter is running ok.

iii) With the help of a Voltmeter, Ammeter, Switch and a Stop Watch:- Connect the Switch (SW), Voltmeter (V) and Ammeter (A) as shown in the following circuit diagram:

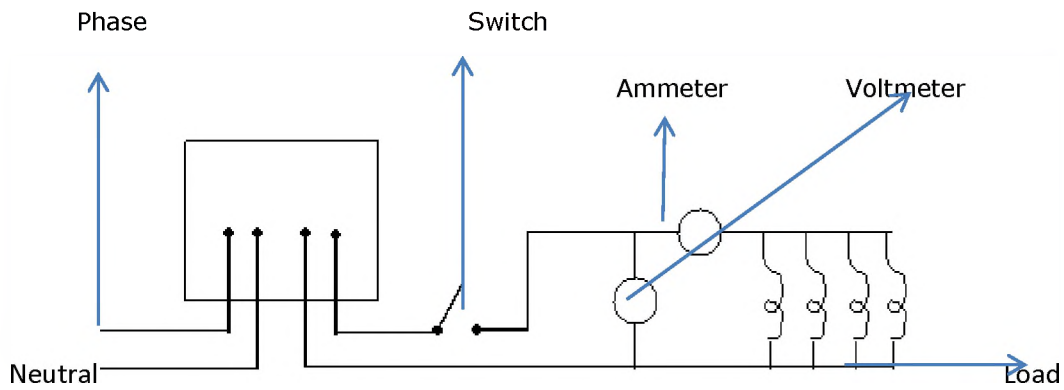

Switch of the supply through Switch 'SW' Note down the initial reading of energy meter of the switch ON note down the reading of Voltmeter and ammeter. Let the energy meter run for 10 minutes. Again note down the energy meter reading after 10 minutes. A set readings may be obtained after an interval of 5 or 10 minutes and noted in the following note

S. No.	Energy Meter Initial Reading (kWh) (X)	Energy Meter Final Reading (kWh) (Y)	V (Volts)	I (Amps)	I (Seconds)	Energy by calculation = $VIt/1000 \times 3600$ (kWh)	Energy Meter Reading (X)-(Y) (kWh)

Compare the meter reading and standard energy consumption noted through calculations. You would come to know the correctness of the functioning of energy meter.

What is the basic difference between the working of old electromechanical meters and new electronic meters? Why the utilities have switched over to new electronic meters when both are ISI marked?

Electromechanical Energy Meter (Old Meters)- Most of the residential buildings have got single phase, two wire power supply (one phase and one neutral wire). The typical connections, accordingly are shown below:

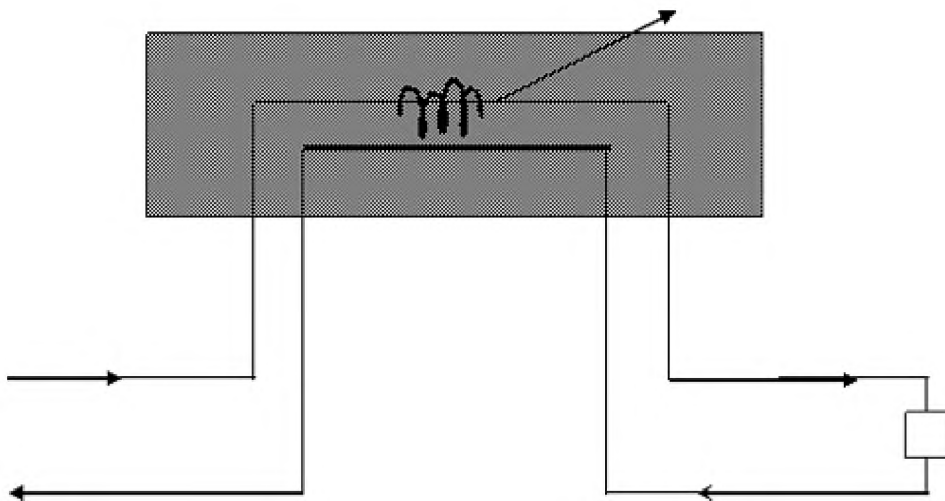

* Load i.e. lamps, tube lights, fans, coolers, geysers, refrigerator and other electrical appliances, which consume electrical energy.

Electromechanical Energy Meter - SCHEMATIC Diagram

As shown above, in the conventional energy meter, the measuring element (which senses energy consumed is provided only on phase circuit does not have any such measuring element.

For a non-technical person/common consumer, it can be explained that energy/current enters the meter through phase wire, passes through the measuring element of energy meter, reaches lamps/electrical gadgets, etc. in the house and goes back through neutral wire as can be seen above in the typical diagram.

The conventional energy meter records energy based on the current, which enters the energy meter and is measured by the measuring element installed in the phase circuit.

Keeping above working principle in mind, the electromechanical energy meters were earlier installed by the Electricity Boards/Utilities/Contractors at the residence and wiring of phase and neutral was also accordingly done.

Neutral wires in the house in some of the multi-storey building were joined together by the electrical contractors for economy reasons/easy connections in less time and the meters as such were working fine with that wiring arrangement.

Problems Encountered by Distribution companies in electromechanical meters As no measuring element was used in return circuit i.e. neutral wire in electromechanical meters as indicated in the above diagram tampering was easily possible in such meters e.g. reverse phase running, etc. In a tampered meter, it is possible to run the meter as and when required with simple operation of a toggle switch.

To deal with tampering problems, a need was felt to have a meter, which has measuring element in neutral circuit also as shown below:

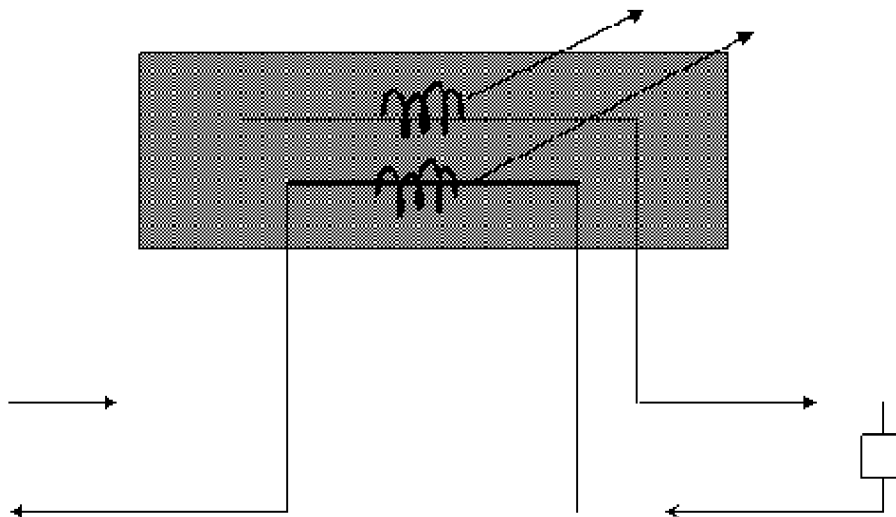

* Load i.e. lamps, tube lights, fans coolers, geysers, refrigerator and other electrical appliances, which consume electrical energy.

Electronic Energy Meter – Schematic Diagram

Electronic Meter - In order to minimize the possibilities of pilferage of energy through tampering of meters, have more accurate recording of energy consumption and have meters, which do not get appreciably affected by mechanical and magnetic disturbances, use of electronic meter was started

by electricity boards/utilities. The typical schematic diagram of electronic meter indicated above may be seen.

With above features in place, the electronic meters started recording readings even if some tampering had been done with the meter. Manufacturing have provided indicating lights i.e. LEDs also in some of the electronic meters, which help the utilities to detect tampering or wrong connections done, if any, if inadvertently, the connections have been done wrongly within the meter at the time of manufacturing or at the time of installation e.g. load side connected to supply side etc., then also the LED on the meter will glow indicating that something wrong has taken place. Therefore, we must keep a vigil on these LEDs mounted on the energy meters as wrong connections can also make the meter run fast. If such LEDs keep on glowing, then we must inform the utilities for doing the needful Generally, LED for 'Power On' glows when power is ON and LED for 'CA:' (i.e. calibration) blinks when meter is recording energy consumption. Other LEDs on the meter, if glow indicate that some wrong connections/ tampering with meter has been done.

In addition to having measuring element in neutral circuit, electronic meters have one more built-in feature i.e. comparator which compares the current flowing between the phase measuring element and neutral measuring element. This comparator senses both these currents, and considers only the higher value of current for energy metering.

So, in order to enable the utilities to trap the fraudulent consumers and to raise more accurate bills for the energy consumed by its consumers, the following important additional design features have been incorporated in the present electronic meters:

- a) Measurement of current in neutral/return circuit in additional to phase circuit;
- b) Measurement of higher of the tow currents (one measured by measuring element in phase circuit and other in neutral circuit);
- c) Sensitive/more accurate recording of energy consumed and
- d) Not prone to easy tampering

If electronic meters are working satisfactorily, then why did you receive inflated bills? Has it something to do with neutral connections?

As stated in Answer No. 2 improper neutral connection is also one of the reasons for fast running of meters and hence inflated bills.

When old electromechanical meters were replaced by new electronic meters and were pressed into service, a practical problem in. it is due to the neutral connection wiring which was done earlier keeping in mind the characteristics of electromechanical meters, which did not have measuring element in neutral circuit and did not get affected by neutral wiring/joining. The problem is however more prominent in the case of multi-storey buildings where more than one energy meters are installed on common bus bar (at one place/side-by-side).

Let us try to understand the problem with respect to improper neutral connections through details and illustrations given below:

1. Please see Illustration 1.

Illustration 1

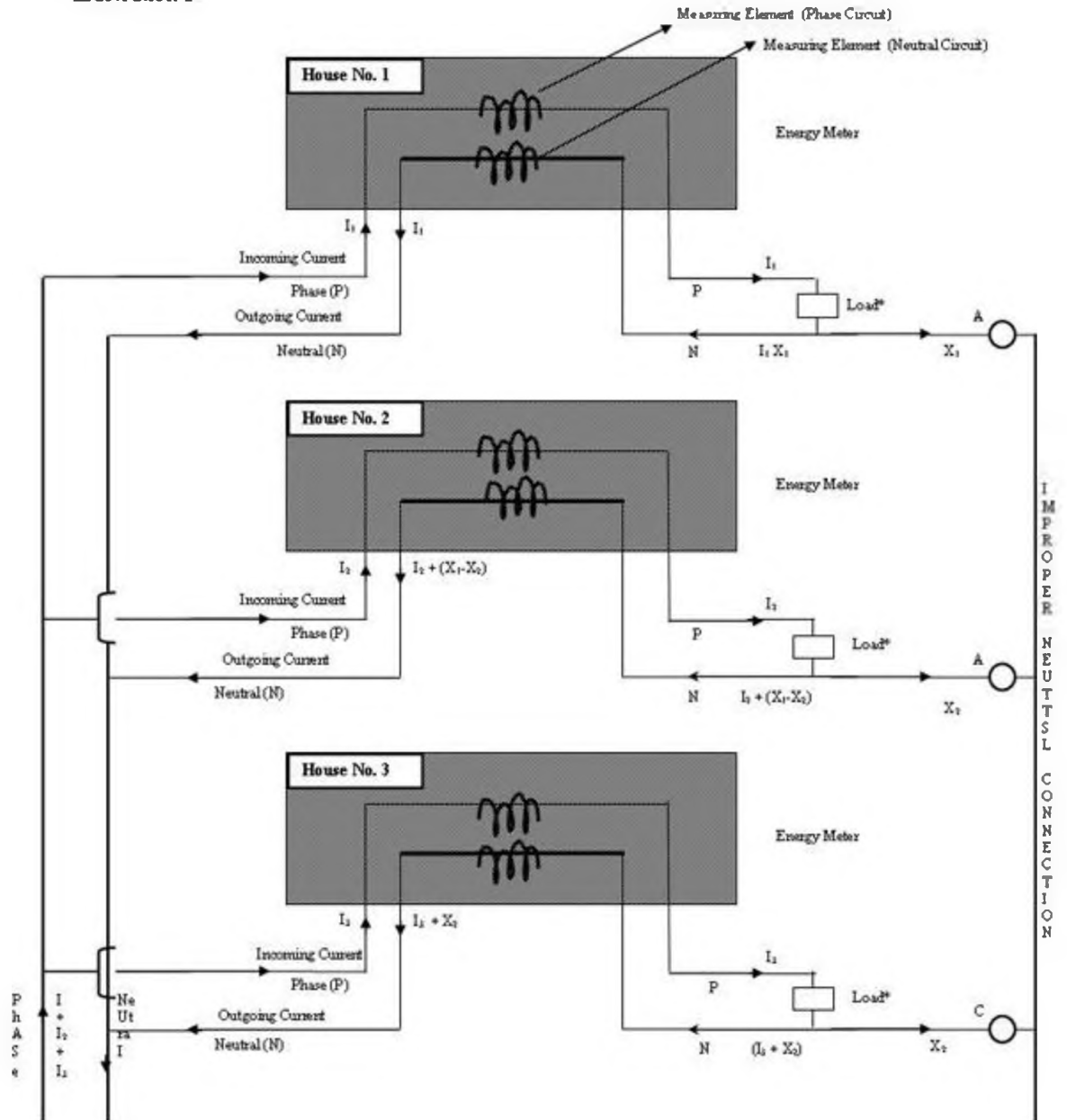

* Load i.e. refrigerator, lamps tube lights, fans, coolers, geysers and other electrical appliances which consume electrical energy.

i) In case of House No. 1 I_1 current is entering the house and $I_1 - X_1$ current is going out of the house/meter. Since I_1 is more than $I_1 - X_1$, therefore the meter will register energy corresponding to load current I_1 which is okay.

ii) In case of House No. 2, I_2 current is entering the House and $I_2 + (X_1 - X_2)$ current is going back. Since $I_2 + (X_1 - X_2)$ is more than I_2 , therefore, in this case, the neutral measuring element will start sensing and the meter will record energy as per $I_2 + (I_2 - I_2)$ which is higher than the actual energy consumption of House No. 2.

iii) In case of House No. 3 I_3 current is entering the House and $I_3 + X_2$ is returning back through neutral which is higher than I_3 . Therefore, energy corresponding to $I_3 + X_2$ will be recorded by the electronic meter which is more than the actual energy consumption of House No. 3.

the consumption on House No. 1 & 2 both (corresponding to current I1 + I2 in the neutral circuit)

If meter is running ok and neutral connections are also in order, then what could be the other reasons for increase in the billing amount?

One reason could be the more accurate and sensitive nature of the electronic meters as compared to electromechanical meters. The electromechanical meters, with the passage of time and also by virtue of their design, did not record energy if consumed in very small quantity. They were generally of class 2. But the electronic meters in addition to being sensitive have accuracy of class 1 i.e. they can record energy within an accuracy of + 1% so, now, whatever small energy consumption we have by virtue of indicating lights, LEDs on switch boards, leakage of current due to old house wiring etc., gets recorded by highly sensitive and more accurate electronic meters.

We may also not be aware of the fact that some equipment e.g. TVs, DVDs, etc. when switched off through remote controls continue to consume energy unless they are switched off from the switch mounted on the equipment itself.

Thus we find that there occurs a continuous waste of precious electrical energy (almost 24 hours energy drain). It is true that because of above reason there would be marginal increase in the electricity bill but then why unnecessarily pay for the energy, which in fact has not been utilized by us for fulfilment of our necessities or comfort Let us remember, "Energy Saved is Energy Produced".

There could be a personal error on the part of meter reader while taking reading, which may also result in excess billing. The errors in the software used by utilities for computing and generating bills electronically may also be one of the reasons that the bills are inflated. For such reasons, distribution companies may be approached with a request to issue revised bills for the actual energy consumed.

It is also true that electromechanical meters, which were installed a few years ago, had started running slow due to moving components in the meter getting worn out. Now since electronic meters have replaced old meters and electronic meters are accurate and sensitive, new meters have started recording the actual energy consumption when electricity bills generated by new electronic meters are compared with old electromechanical meters, there is a feeling that the bills are inflated but it is only psychological. In fact, old meters with the passage of time had started running slow and new meters are registering actual energy consumption. So, this erroneous notion also needs to be dispelled.

Do various electricity boards/utilities of different States have different specifications for energy meters?

As per Gazette Notification No. S.O. 189(E) dated 17 Feb. 2003 – Electrical Wires Cables, Appliances and Protection Devices & Accessories (Quality Control) Order, 2003 issued by the Ministry of Commerce & Industry, energy meters have come under mandatory certification w.e.f. 17th August 2003. As per this order, nobody can manufacture, store and sell energy meters without bearing ISI mark. Following three standards have come under compulsory certification scheme of Bureau of Indian Standards (BIS).

- a) IS 13010:2002 - Electromechanical Meters
- b) IS 13779:1999 - Electronic Meter
- c) IS 14697:1999 - Transformer Operated Meters (for bulk consumers)

All the electricity boards/utilities have to ensure as per above Gazette Notification that all the meters purchased by them and installed at consumer's end bear ISI mark, which means that these meters conform to the requirements laid down in relevant Indian Standards.

If any electricity board specifies any additional features in their tender, then manufacturer may provide these features in the meters supplied to electricity boards/utilities but in any case these meters should meet the requirements specified in relevant Indian Standards as indicated above. These additional features may be some constructional requirements or anti-tampering features etc

Do the Indian Standards match with the International Standards with respect to energy meters?

Yes, the Indian Standards on Energy Meters used for domestic purpose have been aligned with the International Electro technical Commission (IEC) standards. The corresponding IEC standards are given below:

	Indian Standard	IEC Standard
i)	IS 13010:2002 ac Watt hour Meters (Electromechanical Meters) Class 0.5, 1 and 2	IEC 60521 Alternating – current Watt hour Meters, Class 0.5, 1 & 2
ii)	IS 13779:1999 Ac Static Watt hour Meters (Electronic Meters) Class 1 & 2	IEC 61036, Alternating – current Static Watt hour Meters, class 1 & 2

Above IEC Standards have been recently restructured at IEC level as follows:

- a) IEC 62053-11, for electromechanical meters
- b) IEC 62053-21, for electronic meters
- c) IEC 62052-11, for general requirements, tests & test conditions of metering equipments.

The above Indian Standards adequately cover the performance requirements including accuracy under the effect of influence quantities like temperature etc. and their methods of tests which are in accordance with the well-established and internationally accepted test methods according to IEC standards.

Do our Indian Standards on energy meters some tests keeping interest of consumers in mind?

There are nearly 30 tests given in Indian Standard for electronic meters (IS 13779:1999) which are of relevance to all the stakeholders i.e. manufactures, utilities and consumers. Out of these 30 tests, a few of the tests of common interest are given below:

- a) Test of running on no-load condition – As per this test, it is ensured that if the consumer is consuming no electrical energy, then energy meter should not run. This test is of more relevance to the consumers and is required to be carried out on each meter by the manufacturer.
- b) Test of starting condition: This test has more relevance to the electricity boards/utilities. As per this test, the meter shall be fully functional within 5 seconds after the power supply is switched ON. The meter shall start and continue to register energy consumption at 0.4% of basic current (for a Class 1 meter) of the meter e.g. a 0-10 A meter should start running at 0.04 A i.e. at 40 milliamp ere of current i.e. at about 7-8 W of load. Similarly, a 0-5 ampere meter should start (registering energy even if as small as about 3.5-4 W load is connected to it. Manufacturers are required to carry out this test also on each meter.
- c) Test of accuracy requirements – Manufacturer, at his end, calibrates meters with a duly calibrated standard meter of higher accuracy to ensure that error of each and every meter is

within limits specified in Indian Standard (at different values of current and power factor). Most of the electronic meters are of class 1 accuracy as against class 2 accuracy of electromechanical meters. The permissible limits of error of class 1 meter are $\pm 1\%$ at basic current and unity power factor. This means that recording of energy consumption in electronic meters of class 1 accuracy is very accurate from the consumer as well as electricity boards/utilities point of view. The average consumption of a household varies depending upon their individual consumption pattern. Presuming that energy consumption is 400 units per month and meter is operating at an error of $\pm 1\%$ the indicated consumption would vary by ± 4 units per month at the most.

It may be noted that records for all tests including the above tests (which are carried out on whole production as per Scheme of Testing & Inspection (STI) prepared by BIS and accepted by manufacturers) are maintained by the manufacturers who have been granted license by BIS under its product certification scheme. BIS verify these records periodically through surprise inspections during which testing in factory, sampling for independent testing, etc., is also done.

How to calculate approximate units of electricity consumed in a house and compare it with electricity bill received for a particular month?

One unit (kWh) of electricity consumed means 1000 watt of electrical energy consumption in one hour. Approximate wattage consumption per month may be calculated as follows:

Details indicated above are for reference only. Exact wattage of any appliance may be seen from the rating plate affixed on the appliance. Based on the same and actual number of hours it is run/operated, one can compute the actual energy consumption per day and when it is multiplied by 30/31, we can find out the energy consumption per month by that appliance. Further, based on electricity tariff, we can on our own, cross-examine the monthly electricity bill which indicate the units consumed in kilo-watt hours (kwh) and amount to be paid by us for the electrical energy consumed by us. This cross-verification of units consumed in our house would at least give us an idea that whether our electricity consumption recorded by electricity meters installed by power distribution companies and indicated in electricity bills are comparable and satisfactory or not.

However, we may not forget that apart from the energy consumption in appliances indicated above, there is some energy, which is also consumed by equipment like indicating lamps on switch-boards; transformer operated equipment; batteries under charging; gadgets which are not properly switched off (switched off through remote only) and continuous drain of electrical energy through old house-wiring etc. This energy consumption may also be taken into account while calculating number of units consumed every month.